

PlateWriter™ 4200

- the next generation iCtP™

iCtP™



- Affordable, easy to use inkjet CtP system
- Environmentally friendly, no processing chemicals
- Reduces plate production costs

GLUNZ & JENSEN 

THINK NEW - GO FURTHER

Glunz & Jensen, the company

Glunz & Jensen is dedicated to creating and delivering proprietary products with superior lifetime cost of ownership to the printing and pre-press industry.

The Glunz & Jensen innovation team that developed the industry's leading film and CTP plateprocessors now provides a groundbreaking new solution: iCtP – Computer to Plate, based on inkjet technology.

The PlateWriter series of platesetters and the range of accompanying iPlates bring many of the advantages of CTP to printers using conventional offset presses, resulting in increased plate production and improved press room operation.



Caring for our environment

Caring for the environment is an ever increasing concern for today's printer. The Glunz & Jensen iCtP system uses a unique additive plate-making solution to address this issue, making it totally free of processing as well as eliminating the associated chemical disposal costs.

Both the imaging system iCtP and the iPlates operate in daylight conditions, requiring no special handling. The system is easy to use, offers higher quality printing at lower costs and provides maximum efficiency by eliminating many of the steps and variables involved in preparing offset plates.

With well over 100,000 film and computer-to-plate processor systems installed throughout the world, Glunz & Jensen is renowned for its superiorly built quality and reliability. Now this industry-leading expertise is available in the shape of revolutionary low cost CTP solutions. Advice and demonstrations are readily available.



- Reduces costs
- Affordable
- Easy to use
- Environmentally friendly
- High quality output
- Color proofing
- Flexibility

The world's leading CTP processing equipment supplier, since 1973

GLUNZ & JENSEN



PlateWriter™ 4200

- the next generation iCtP™

The industry's first inkjet Computer-to-Plate system capable of producing press-ready aluminium plates without chemical processing. The PlateWriter™ 4200 inkjet boasts innovative technology and sets new standards for the cost, flexibility and speed of offset printing for small to medium format printing.

The PlateWriter™ jets a patented Liquid Dot™ solution onto non-photosensitive aluminium plates. The imaged plates are manually fed through a finishing unit that dries the plates and bonds the liquid dots. The plate-finishing unit has a built-in gumming station to finish the plates and protect them from damage before going to press.

PlateWriter™ 4200 System:

Inkjet Print Engine

The PlateWriter™ 4200 uses a customized, heavy duty inkjet imaging platform (Roland SP-300) ensuring repeatable and accurate registration of plates.

Finishing Unit

Imaged plates must be fed through this unit, located below the Print Engine. It finishes the plates by drying and bonding the liquid dots to the plate surface. The Finishing Unit includes a built-in gumming station to apply a protective gum layer.

Liquid Dot™

The patented Glunz & Jensen imaging solution. This formulation is jetted onto the plate surfaces in the same manner that ink is jetted onto paper in a traditional inkjet printer. Liquid Dot™ is supplied in 110 or 220 ml cartridges.

Software & Proofing Support

Xitron RIP – a Harlequin based RIP which has become an industry standard due to its ease of use and integration with other workflows. Supports the full line of proofing solutions from Epson.

Plates

Grained, anodized and non-photosensitive aluminium plates. Glunz & Jensen's certified plates will be made available through our approved resellers.

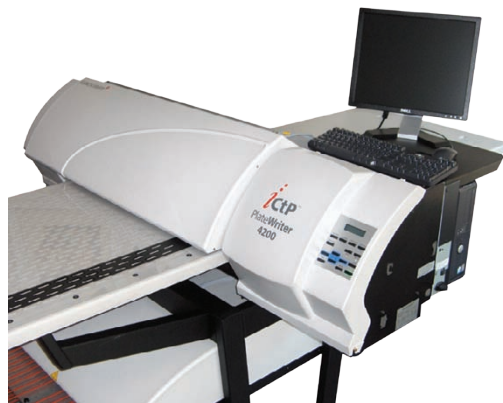

Optional RIP stand



Harlequin based Xitron RIP
Glunz & Jensen PlateWriters are powered by Harlequin RIP Technology to ensure industry standard compatibility



Easy to Use

The PlateWriter 4200 provides clean, accurate digital plates, direct from your desktop.

Versatile platemaking for all 2 & 4 up presses

The patented plate alignment system allows users to easily change plate sizes by simply positioning the new plate on the alignment mat.

The Glunz & Jensen eXact Registration Technology loads the plate and uses vacuum to keep it in registration. Plate sizes from 127mm (5") x 127mm (5") upto 675mm (26 1/2") x 915mm (36")

Powered by Harlequin RIP technology



Print jobs direct from your application on a Mac or PC – like you would with a normal desktop printer. Or you can use Hot folders on your computer or a network to drag and drop Postscript, EPS, Acrobat PDF, JPEG or TIFF files. Jobs can be delivered in a pre-separated format or the RIP can be set to separate jobs as they arrive, making it compatible with virtually any application or platform. The user can then preview the jobs and select which should be imaged to plate.

Great results in broad daylight



By using conventionally grained aluminium plates without thermal or light sensitive coatings, the PlateWriter 4200 can be used in full daylight conditions. No special precautions are required! You simply place a plate onto the alignment mat and press the LOAD PLATE button on the front of the PlateWriter. The alignment and registration mat, carrying the plate, will automatically feed back into the PlateWriter and register your plate.

Simple and clean operation



Once a job is released from the RIP workstation the PlateWriter™ uses high definition inkjet technology to jet a patented Liquid Dot™ chemical solution onto non-photosensitive aluminium printing plates. There is no light or thermally sensitive coatings associated with conventional CtP, so there is no coating to remove thus no processor and no need for processing chemistry.

Accurate press ready plates

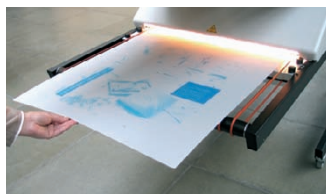

Directly imaged digital plates direct from your desktop are consistent and accurate, which reduces time on press for registration. The iCtP bonds the liquid dots to the plate surface. After imaging on the PlateWriter, the plates are automatically gummed in the integrated iCtP finishing unit. Then they are ready to go right on the press or be stored for later use.

Technology designed to support you

Additive Platemaking removes the need for chemistry or plate processors

Conventional plate making is a subtractive process. A conventional printing plate has a coating, which is sensitive to exposure through UV light or from thermal or visible energy delivered by laser.

An image is exposed onto the plate's sensitized coating and then the plate is processed by chemistry that removes the unwanted areas, revealing hydrophilic the Aluminium grain (non image areas).

Glunz & Jensen's additive approach

iCtP uses the same aluminium plate, but without the sensitized coating. Advanced inkjet technology

jets a patented Liquid DOT formulation onto the plate to add the areas we want to be oleophilic on the printing press. The plate passes through the iCtP Finishing unit to bond the image on to the plate.

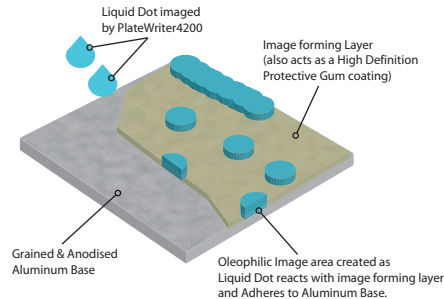

The added advantage of sophisticated proofing support for Epson proofing printers



By integrating proofing support for Epson 4800, 7800 & 9800, Glunz & Jensen has made the PlateWriter 4200 ideal for small print shops and commercial printers.

Most digital proofing solutions provide a four colour composite proof. However, many print shops are producing four-colour process work on a two tower press, meaning that the sheet must run through the press twice.

The iCtP proofing solution provides a high quality composite proof and also a more practical 'progressive proof' in any combination of one, two, three or four colours for users of one or two tower presses. Furthermore, the same RIP controls your platemaker and the proofing printer – what you see on the proof is what you will get on the plate.

In addition iCtP Proof allows users to produce plates for the PlateWriter while printing proofs using the Epson printer. The multi-tasking functionality saves time and increases productivity.

For the ultimate in colour proofs and colour matching, the proofing can be upgraded with 'Harlequin ColourPro' plugin. It enables ICC profiling and delivers Harlequin's 'ProofReady' profiles, pre-built for Epson papers and inks. It is virtual 'Contract Ready' proofs for all your process colour jobs - right out of the box!

iCTP-Proof software – the intuitive and practical approach to progressive and process colour proofs

You decide to run cyan and yellow on the first pass through a two-colour press. iProof allows you to print a proof of the colours, resulting in less guess work and greater accuracy.

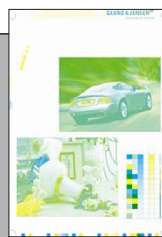

On the second pass through the press, magenta and black ink are added ...



Resulting in the final CMYK-colour piece (which you also run a proof).



Powerful options to enhance your PlateWriter

i-Position

Powerful and dynamic Imposition solution with Hot Folder integration for building Digital Workflows with your iCtP RIP.



Designed for PDF and PS workflows, I-Position includes comprehensive imposing tools for iCtP users enabling automated booklet & magazine creation. I-Position will also Step & Repeat smaller jobs allowing maximum use of press sheets and reduced time on press.

I-Position delivers an imposition solution that is everything you need for all you can imagine.



Trap PRO Full Feature Automatic In-RIP Trapping Solution

Introduces areas of color into color separations to obscure potential register errors when printed. The errors are usually caused by paper shift, paper stretching, or an incorrectly aligned press. To compensate for this, traps must be added to the areas where gaps or overlays are most likely.

Traditionally, a skilled press operator would spread or choke the ink to make the gaps less noticeable. And the page designers would attempt to 'design out' any potential misregistration. Both methods require great skill and time to perfect.

TrapPro automates this process and provides a solution which removes the guess work, improving both the quality and consistency of printed output.

PlateWriter™ 4200

Technical specifications

iCtP™

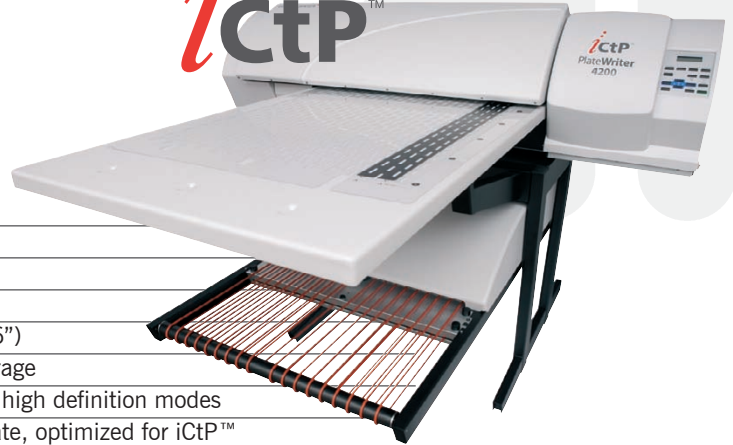

Imaging device:	540 nozzle, Ultra high definition printer
Imaging fluid:	Patented Liquid Dot™ technology
Special lightning:	Not required - Day Light safe
Plate dimensions:	All 1- to 4-up formats
Format size max.	(W x L): 675 mm (26 1/2") x 915 mm (36")
Speed:	Dependent on Plate format and image coverage
Image quality:	User selectable fast, high quality and super high definition modes
Plate type:	Uncoated grained & anodized aluminum plate, optimized for iCtP™
Plate thickness:	Aluminum 0.15 / 0.20 / 0.30 mm (0.006 / 0.008 / 0.012")
RIP:	Harlequin based RIP platform: 1GB RAM, 100 Base T ethernet with connectivity to MAC & PC environments
Screening:	Stochastic screening, optimized for iCtP™ ensuring moiré free prints
Plate processing:	Not required
Processing chemicals:	Not required
Plate finishing:	Automated integral gumming system
Footprint (L x W x H):	2425 mm x 1725 mm x 1250 mm (95.4 x 67.9 x 49.2")
Power supply:	100 to 230VAC, 50/60Hz
Power consumption:	Stand by: 0.3 kW- process: 3 kW
Operating environment:	Temperature range 15 - 32°C (59 - 90°F); 20°C (68°F) or higher recommended
Humidity range:	35 to 80% (no condensation)
Weight:	200 kg (441 lbs)

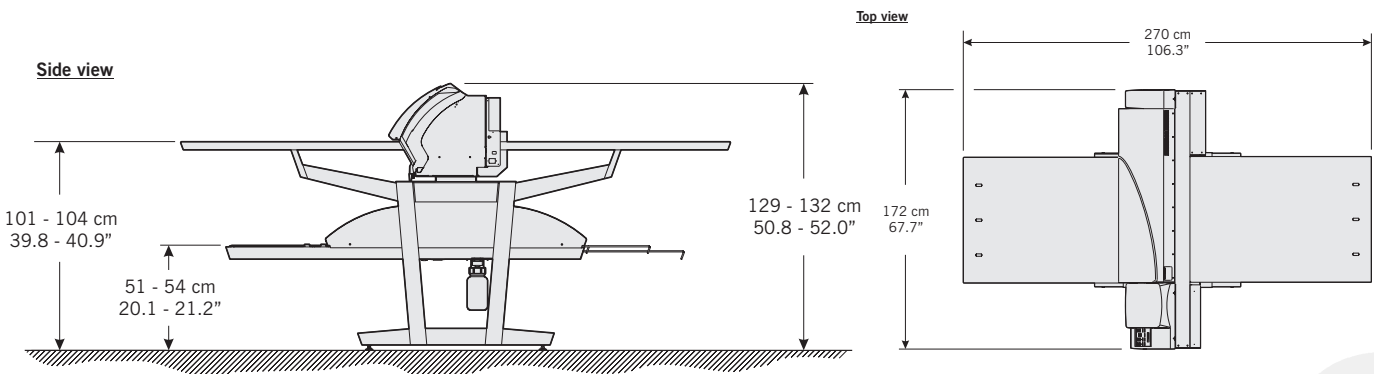

GLUNZ & JENSEN

Headquarters:
 Glunz & Jensen A/S
 Haslevvej 13
 DK-4100 Ringsted
 Denmark
 Tel. +45 57 68 81 81
 Fax +45 57 68 83 40
 E-mail: gjhq@glunz-jensen.com
 Internet: www.glunz-jensen.com

USA Operations:
 Glunz & Jensen, Inc.
 21405 Business Court
 Elkwood, VA 22718-1757
 USA
 Tel. +1 540 825-7300
 Fax +1 540 825-7525
 E-mail: usva@glunz-jensen.com